

179 Margery 14

HOUDINI

Exposes the tricks used by the
Boston Medium "Margery"
to win the \$2500 prize offered by the Scientific American.

Also a complete exposure of
ARGAMASILLA

The famous Spaniard who baffled noted Scientists of Europe
and America, with his claim to

X-RAY VISION



PRICE, ONE DOLLAR

COPYRIGHT BY HARRY HOUDINI, NEW YORK, 1924

*Advance copy -- Book not on sale
until Oct 19/24 -- Regards -- Houdini*

HOUDINI

Exposes the tricks used by the
Boston Medium "Margery"
to win the \$2500 prize offered by the Scientific American.

Also a complete exposure of
ARGAMASILLA

The famous Spaniard who baffled noted Scientists of Europe
and America, with his claim to
X-RAY VISION



PRICE, ONE DOLLAR

COPYRIGHT BY HARRY HOUDINI, NEW YORK, 1924

ADAMS PRESS PUBLISHERS, 270 West 113th Street, New York City

EX LIBRIS



WILL ALMA

M.I.M.C. (LONDON)

The State Library of Victoria
"ALMA CONJURING COLLECTION"

"Margery" the Medium Exposed



A. HOUDINI B. J. MALCOLM BIRD
C. MARGERY D. MR. O. D. MUNN

IN order that the reader may thoroughly understand my relation to the "Margery" case and the *Scientific American*, and to make this record as complete and clear as possible, I will first review briefly my connection with that magazine's investigation of so-called psychic phenomena.

Something like three years ago I was asked to write a series of articles on Spiritualism for the *Scientific American* but had to refuse owing to pressure of work. Later a Mr. James Black furnished the magazine with a number of articles which were published, but these were so inaccurate that they were assailed, and justly so, from all sides.

Having thus stirred up a hornets' nest and not having a sufficient knowledge of Spiritualism to meet the situation, one of the oldest editors on the *Scientific American*, and my friend for over a quarter of a century, Mr. A. A. Hopkins, wrote me again, urging that I prepare some articles on Spiritualism for them. The letter was followed very soon by a call from Mr. Hopkins who came to my office in New York bringing with him a tall man whom he introduced as J. Malcolm Bird, also a member of the *Scientific American's* editorial staff.

They discussed the Black articles with me and asked why it was that I would not write on Spiritualism for them. I explained that the research work involved was such that I could not entrust it to anyone else and that it was impossible for me to spare the time which this and the writing of

the articles would require, but I advised them to form an investigating committee and said if the other members were honest, reliable, and qualified, I would serve as one without pay with the stipulation that I was to have the right to reject any person proposed as a member of the committee with me. My reason for this was, as I explained to them, that while an ordinary investigator, whether layman, professor, or scientist, could make a mistake and later correct himself without damage to his standing, I was in a different position, for due to the peculiar nature of my work my reputation was at stake and I could not run the risk of having it injured. This was agreed to before they left my office, but sometime afterwards hearing that they had selected a committee without consulting me I wrote the following letter to protect myself.

November 13, 1922.

MR. J. MALCOLM BIRD,
SCIENTIFIC AMERICAN,
233 BROADWAY,
NEW YORK CITY.

DEAR MR. BIRD:

I have just been informed by Mr. Hopkins that you have already selected a committee to serve as investigators for the \$5,000.00 offered to the mediums.

So, that there is no mistake in this, I would like to have it understood emphatically, that when I consented to be one of your committee, it was under the condition that,

1. I am to know each and every man so selected.
2. That all conditions placed before the mediums should be thoroughly gone over with me, so that there could be no loop-hole for anyone to misconstrue the conditions of the manifestations required.
3. Another condition is that the selected committee will go to a number of seances for investigation purposes, so that we could get a line on each other regarding the capability of actually recording in writing what was seen, as mal-observation is the curse of all description.

It was also stipulated in my conditions that we are to hold conferences to see whether all the committee are agreeable to each other, because we must work in harmony.

I have more at stake than the money you are offering, and that is, my reputation as a psychic investigator, and I, therefore, ask you to give me your full confidence, as I am giving you mine. I intend to serve you faithfully, and with all the knowledge I possess, but I ask to be fully protected in this.

May I suggest that it might be advisable for us to get together again before publicity is given, so as to prevent any mistakes on all our parts. I am keenly and intensely interested in the subject and will deem it a compliment to be on the committee, but if any of the above conditions do not meet with your approval, please count me out.

Yours sincerely,

HOUDINI.

HH.JLD

The Committee as finally formed consisted of Dr. William McDougall, of Harvard University; Dr. Daniel F. Comstock, formerly of the Massachusetts Institute of Technology; Dr. Walter Franklin Prince, of the Society for Psychical Research; Hereward Carrington; and Houdini. Mr. Bird has acted as Secretary for the Committee and Dr. Austin C. LeScaboura, another editor on the *Scientific American* Staff, has assisted in arranging the tests and been present at most of the seances.

Following the *Scientific American's* offer of a sum of money as a prize to any medium who could successfully pass its tests, several presented themselves and gave sittings before the Committee. Among them were the Tomsons, Mrs. Josie Stewart, Valentine, and Pecararo. Bird did not invite me to the major part of the séances, whereas, as Secretary, it was his duty to do so, therefore, on learning of the Pecararo tests, I traveled from Little Rock, Arkansas, to New York, to be present at one of the Pecararo séances.

In all these investigations it would seem that Mr. Bird allowed the mediums to believe that they had practically won the prize and this is mirrored in the press reports given out by him. Dr. Prince and I strenuously objected to this course.



A. DR. WALTER FRANKLIN PRINCE C. MARGERY
 B. DR. DANIEL F. COMSTOCK D. MR. O. D. MUNN
 E. HOUDINI

So far as I knew there was no other investigation under way when, on picking up a copy of the *Scientific American* early in 1924, I was surprised to find an announcement of a series of séances being held by the Committee with a certain "Margery" and judged from the reading of it that the Committee was on the verge of awarding her the prize. In the next issue of the magazine I again found mention of the mysterious medium whose identity was being hidden behind the name of "Margery," but as most all American papers carried stories giving her correct name and address before I was called into the séances, and as later she gave interviews to newspaper men, and one in particular in my presence, without denying her name, it would be ridiculous for me now to do other than call her by her right name also, Mina Crandon, wife of L. R. G. Crandon, a well-known Boston surgeon.

The *Scientific American* reports, written by Editor Bird, were such as to lead an ordinary layman to believe that the magazine had found a medium who had successfully passed all its crucial tests and to all intents and purposes was "genuine." In addition the lay reader, and the uninitiated reporter as well, were left with the impression that the Committee had approved this medium, whereas the articles only represented the opinion of Mr. Bird, who, garbing himself in a mantle of authority, had written whatever he desired, always, however, being careful to so phrase his material that later, in case the necessity arose, he could claim a certain alibi. A careful reading of the articles makes these subtleties obvious.

These articles, written by Bird, are the worse piffle I ever read, paralleled only by the tommy-rot written about Mrs. Guppy, who was said to have been floated through the air, plate-glass window, and solid brick.* Bird represented the medium as not only doing the ordinary table tilting, lifting and communicating by means of a code of raps common among all mediums, but in addition, such stunts as stopping and starting clocks, tipping over the cabinet, having furniture moved around the room before the observers in full light and with no visible means of accomplishing it, Spirits whistling a tune, using a megaphone, and sending a curtain rod sailing around the room. They also claimed the transportation of a live pigeon through solid matter. They are fulsome, gushing reports of nothing, and to intimate that a live pigeon had been brought into the room from the outside, passing through glass or brick without making or leaving an aperture, is doing something which a magazine with such a reputation for conservativeness and accuracy as the *Scientific American* should avoid, even though the idea is covered.

Shortly after the appearance of the articles, I received the following letter from Mr. Bird:

SCIENTIFIC AMERICAN,
233 BROADWAY, NEW YORK.
June 18, 1924.

MR. HARRY HOUDINI,
278 WEST 113TH ST.,
NEW YORK CITY.

MY DEAR MR. HOUDINI:

As you will observe when you get your July *Scientific American*, we are engaged in the investigation of another case of mediumship. Our original idea was not to bother you with it unless, and until, it got to a stage where there seemed serious prospects that it was either genuine, or a type of fraud which our other Committeemen could not deal with. Regardless of whether it turns out good or bad, there will be several extremely interesting stories in it for the *Scientific American*; and these will run in the August and following issues.

Mr. Munn feels that the case has taken a turn which makes it desirable for us to discuss it with you. Won't you run in, at your convenience, to take lunch with one or both of us, and have a talk with Mr. Munn? Better call me in advance, and make sure that he and I will be in at the time you select.

Faithfully yours,

(Signed) J. MALCOLM BIRD,
Associate Editor.

P. S. Mr. Munn left the office today, to be gone until Monday morning.

I made the appointment requested in the letter and on meeting Mr. O. D. Munn he explained that he had been anxious to get in touch with me, and in fact had been trying to for a week, but Bird had been side-

* See *A Magician Among the Spirits*, page 230.

stepping the matter, and that he thought we should go to Boston together and sit in at the "Margery" séances. After we had talked the matter over he called Bird into his office and turning to him I asked point blank: "Do you believe that this medium is genuine?"

I asked him this because; although a raw amateur at investigating, which amounts to a profession in itself, and with no experience with or knowledge of "the production of mysteries" he had nevertheless, given his approval to several mediums and failed to detect their conjuring trick methods. His reply, as near as I can remember, was:

"Why, yes, she is genuine. She does resort to trickery at times, but I believe she is fifty or sixty per cent genuine."

"Then you mean that this medium will be entitled to get the *Scientific American* prize?" I asked.

"Most decidedly," he answered.

"Mr. Bird," I replied, "you have nothing to lose but your position and very likely you can readily get another if you are wrong, but if I am wrong it will mean the loss of reputation and as I have been selected to be one of the Committee I do not think it will be fair for you to give this medium the award unless I am permitted to go up to Boston and investigate her claims, and from what you tell me I am certain that this medium is either the most wonderful in the world or else a very clever deceptionist. If she is a fraudulent medium I will guarantee to expose her and if she is genuine I will come back and be one of her most strenuous supporters."

Then turning to Mr. O. D. Munn, I said:

"If you give this award to a medium without the strictest examination every fraudulent medium in the world will take advantage of it. I will forfeit a thousand dollars if I do not detect her if she resorts to trickery. Of course if she is genuine there is nothing to expose, but if the *Scientific American* by any accident should declare her genuine and she was eventually detected in fraud *we would be the laughing stock of the world*, and in the meantime hundreds of fraudulent mediums would have taken advantage of the error."

"Well, then you and I will go up together and see," he replied.

"All right, I am at your service," I told him.

This was the condition of affairs on July 23, 1924, when Mr. O. D. Munn and I reached Boston, where Bird had preceded us by auto and was the guest of the medium and her husband, as he had been previously for weeks at a stretch, at times accompanied by Mrs. Bird and at other times alone. Carrington had also spent a number of weeks in the family, but, although we had dinner with the Crandons, Mr. O. D. Munn and I stopped at a hotel, for I agree fully with Dr. Prince that it is not possible to stop at one's house, break bread with *him* frequently, then investigate *him* and render an impartial verdict.

We were given to understand that this first séance which I attended on the evening of Wednesday, July 23rd, was the forty-eighth in which Mrs. Crandon had been tested, but I learned later from a letter written by her husband that it was nearer the eightieth, and by the time Mr. O. D. Munn and I had finished our fifth séance Dr. Crandon claimed that the total was ninety. All séances were *dark*.

At this séance Dr. Crandon sat on the medium's right and held her right hand and J. Malcolm Bird, as had been customary in their previous

séances, circled with one of his hands the fingers of both the medium and her husband. This left one of Bird's hands free for "exploring purposes" as he said.

I sat on the left of Mrs. Crandon and held her left hand with my right. My right foot was placed against her left foot, pressing against her ankle.



FIG. 1.

Anticipating the sort of work I would have to do in detecting the movements of her foot I had rolled my right trouser leg up above my knee. All that day I had worn a silk rubber bandage around that leg just below the knee. By night the part of the leg below the bandage had become swollen and painfully tender, thus giving me a much keener sense of feeling and making it easier to notice the slightest sliding of Mrs. Crandon's ankle or flexing of her muscles. She wore silk stockings and during the séance had her skirts pulled well up above her knees.

One of the successful (?) demonstrations which she had been giving, and which none of the Committee had been able to expose, involved the use of an electric bell enclosed in a box fourteen inches long by six wide and five deep.

This box (Fig. 1)* was stoutly fastened on all sides except the top, which was covered with boards. Inside the box with the bell were dry batteries which rang it whenever a certain pressure at the top of the box completed the circuit. In previous séances when this box had been placed in front of Mrs. Crandon and the sitters supposed they had her perfectly controlled (held by hands and feet so they could detect any motion) the bell had been rung repeatedly and the explanation given was that "Walter," the medium's dead brother, had closed the circuit. Not only had the bell been rung but it had been used with a code and answered questions.

* Also see page twenty-four.

On the evening in question the bell-box was placed between my feet with my right foot between it and Mrs. Crandon's left foot. As the séance progressed I could distinctly feel her ankle slowly and spasmodically sliding as it pressed against mine while she gained space to raise her foot off the floor and touch the top of the box. To the ordinary sense of touch the contact would seem the same while this was being done. At times she would say:

"Just press hard against my ankle so you can see that my ankle is there," and as she pressed I could feel her gain another half inch.



FIG. 2.

When she had finally maneuvered her foot around to a point where she could get at the top of the box the bell ringing began and *I positively felt* the tendons of her leg flex and tighten as she repeatedly touched the ringing apparatus. There is no question in my mind about it. *She did this.* Then, when the ringing was over, I plainly *felt her leg slide back* into its original position with her foot on the floor beside mine.

During the second intermission "Walter" asked for an illuminated plaque to be placed on the lid of the box which held the bell* and Bird went to get it. This left the right hand and foot of the medium free. Bird had difficulty in finding the plaque and while he was searching "Walter" suddenly called for "control." (See Fig. 2.)

Mrs. Crandon placed her right hand in mine and gave me to understand that I had both her hands. Bird was requested to stand in the doorway, but without any warning, before he could obey, the cabinet was thrown over backwards violently. *The medium then gave me her right foot also, saying:*

"You have now both hands and both feet."

Then "Walter" called out:

"The megaphone is in the air. Have Houdini tell me where to throw it."

"Toward me," I replied, and in an instant it fell at my feet.

The way she did these two tricks is as follows: when Bird left the room it freed her right foot and hand. With her right hand she tilted the corner of the cabinet enough to get her free foot under it, then

* See page twenty-four.

picking up the megaphone she placed it on her head, dunce-cap fashion (Fig. 3). Then she threw the cabinet over with her right foot. As she did so I distinctly felt her body give and sway as though she had made a vigorous lunge. As soon as this was done "Walter" called for "better control" and she gave me her right foot. Then she simply jerked her head, causing the megaphone to fall at my feet. Of course with the megaphone on her head it was easy and simple for her to ask me or anyone else to hold both of her feet and also her hands, and still she could snap the megaphone off her head in any direction requested. This is the "slickest" ruse I have ever detected, and it has converted all skeptics*



FIG. 3.

The next day Mrs. Crandon told us it would be impossible to either kick or push the cabinet over as it was hinged on the inside and would double up in the middle, but that afternoon Mr. O. D. Munn and I went upstairs alone and while sitting in the medium's chair I put my right foot under the right-hand corner of the cabinet and easily tilted it so that the slightest movement caused it to fall over.

The second séance of Mrs. Crandon's which I attended was on the evening of July 24th, at Professor Comstock's hotel. At this time I discovered without question that she used her head and shoulders to push back the table. Her great asset in disguising the muscular movements which she uses in doing this is the arm chair in which she sits. As she is unusually strong and has an athletic body she can press her wrists so firmly on the arms of the chair that she can move her body and sway it at will without the sitters, who have hold of her hands, detecting the movement (Fig. 4).

* It has just come to me that Dr. Crandon has a somewhat extensive library and in looking through it, I found a number of books explaining the modus operandi of mediums, and some months ago the Austrian medium Ladislaus Laszlo baffled a number of physicians and scientists by producing a stone apport, they failing to detect him. He later on exposed his method for the newspapers. He had the rock hidden under a chair, having smuggled it there before he was searched. In the dark he eventually found an opportunity to put this rock on his head, having managed to get one hand free an instant for so doing. Naturally, the control then holding both hands could not follow his moves. This report was circulated all over the world, and very likely Mrs. Crandon read it and utilized the movement.

That evening I was in charge of her left hand which rested lightly on the palm of my right. With my index finger I could feel her pulse. In fact I used the secret system of the "touch and tactics" of the mind or muscle performer, (I had given performances or tests in this field of mystery) who is guided by the slightest muscular indication in finding a hidden article. *I was able to detect almost every time she made a move. Frequently she stretched out her arms to rest them and once I caught her using this motion as a subterfuge, leaving only her elbow on the chair while she pushed the table with her head (Fig. 5).*



FIG. 4.

"Walter," her guide and aide, is very autocratic, seldom asking anything but usually directing, and this evening he ordered everyone to move back from the table around which we were sitting so that he might



FIG. 5.

gather force. This was simply another ruse on the medium's part, for when all the rest moved back she moved back also and this gave her room enough to bend her head and push the table up and over. *I caught her doing this twice.*

Before going to the séance Mr. O. D. Munn and I had determined to explore things to our satisfaction and had arranged a code of signals. At the séance he sat at my left in the circle, I holding his right hand. At the first movement of the table I pushed his hand under it and let go and began groping around with my left hand. As I did so I felt Mrs. Crandon's head at the edge of the table pushing it up and forward until the box with the bell had slipped off to the floor. I reached over and whispered to Mr. O. D. Munn what I had detected. Then to check up and assure myself of the deception I reached out again into the dark and *she ran her head directly against my outstretched fingers*. I do not think she was more surprised than I. She then said something about losing hairpins and after the séance her hair was loosened. This was done for effect and to offset my discovery.

While I knew she was still using her head, I pulled Mr. O. D. Munn's ear to my lips again and whispered:

"Will I denounce and expose her now?"

"You had better wait a while," he replied.

"Now is the time," I urged.

"No, better not for a while," he answered.

After this demonstration the bell-ringing test was gone through again. The box was placed between my feet with her ankle against my right foot like the night before. I had rolled my trousers up as on the previous evening. She began with exactly the same tactics, but nothing happened. Finally she said to me:

"You have garters on, haven't you?"

"Yes," I replied.

"Well, the buckle hurts me," she said.

I reached down to undo the garter and found that the buckle had caught her stocking so fast that it prevented her from sliding her ankle enough to get room to tap the bell. After I took the garter off she was able to reach the bell as she had the previous night. When the spirit asked Mr. O. D. Munn how many times he wanted the bell rung and Mr. Munn said "five," she made so bold a sliding movement with her ankle to reach the box that I think she was under the impression that I was badly fooled or was going to help her like others. After the five taps on the bell she slid her foot back into position on the floor beside mine.

When the séance was over Mrs. Crandon left the room to dress for the street. I had Mr. O. D. Munn call the Committee into a room by themselves and I explained the trickery which I had discovered and there was a discussion as to whether I should expose the medium then or after our return to New York. The Committee finally decided that we should return to New York first; that Mrs. Crandon was not to be informed that I had detected her, and I was to make an affidavit for the Committee covering the details of my discoveries. *Bird opposed my demands to have her exposed as quickly as possible, but I called his attention to the rapid exposure he had given the others* and he replied:

"We will do it different this time."

I strongly suspected his motives and told Mr. O. D. Munn so after we had left.

Directly after this séance Mr. Munn and I started for New York, although Bird stayed on for three days as the guest of Dr. and Mrs. Crandon and later when called to task before Mr. O. D. Munn admitted

that he gave them information concerning my discoveries and the talk of the Committee. Before I left my hotel that night I wrote the following letter which I handed to Mr. O. D. Munn at the same time telling him that I did not want Bird to write an account of my findings.

July 24, 1924.

THE COPLEY-PLAZA,
BOSTON.

DEAR MR. MUNN:

Please if I may, allow me to see the exposed article before it is published, as all of the other articles were not written so as to properly place the real thing before the public.

Mr. Bird in your presence, said he believed the medium was fifty per cent genuine, when this evening there was no chance of anything she pretended to have been accomplished by "Walter," but was so done by herself. In fact she is *one hundred per cent trickster or fraud* judging by the first séance I attended, after forty or more were given.

I ask you in all *fairness* that in the future, Mr. Bird be not permitted to send any report speaking for the Committee, unless the Committee has read the account and agreed that it should be published.

I have been unfairly treated in this case being only called in when according to Mr. Bird's personal statement and in print made, to the effect that the medium, Mrs. Crandon, was fifty per cent genuine, and publishing in two articles of your publication, facts such that could not have been written by a competent investigator, and I would like a personally written statement from all those who were present on the Committee, to check up their findings.

Most important of all, in the future, the entire Committee should be called to the séances in a systematic manner and not in a haphazard way as has been done.

Believe that whenever material is published in reference to the Committee or work probably to be done by it, that the names should be mentioned and they are not to be treated in a slighting manner.

If any of those conditions do not meet with your approval, will you kindly accept this letter as may resignation.

(Signed)

Houdini.

At this time the September number of the *Scientific American* was on the press and in it was another article by Bird in which he spoke of the "wonderful mediumship of Margery." The first thing Mr. O. D. Munn did when we got to New York was to stop the presses and have this article of Bird's thrown out.

"Houdini; stopping presses and throwing out that thing of Bird's is a pretty costly proposition," he said.

"Yes," I replied, "but it will save the reputation of the *Scientific American*, and that is cheap at any price. Bird has not a penny invested in your magazine, but nevertheless is using it to suit his own purposes."

He evidently agreed with me and as a result when the September number came out it had no reference to the investigation. Bird's articles in the *Scientific American* were so uncalled for, so unreal and so misleading that Dr. Prince and I agreed that they must stop, for Bird was making statements as though Dr. Prince were in accord with him, which was not the case, and it was jeopardizing Dr. Prince's reputation and position. So concerned was Dr. Prince about it that he told me he was going to resign and I replied if he did I should also terminate my dealings with the Committee.

I then made a special trip to see Mr. O. D. Munn, explained the situation to him and told him that if we were going to Boston again I wanted

Dr. Prince retained on the Committee and taken along with us, for I trusted implicitly in his integrity. I got Dr. Prince on the telephone and asked him to come to the *Scientific American* office immediately, which he did, and before leaving he agreed not to resign if the following conditions were adhered to:

1. No reports of experiments with which the judges have to do at any stage, and no opinions, positive or tentative, regarding their results or quality, shall be made public, either in the *Scientific American*, or any other publication, prior to the conclusion of the series of which they are a part. Not only the management of the *Scientific American*, but all the judges shall agree to this.

2. No representative of the *Scientific American* shall ascribe to the Committee of Judges, in that periodical or elsewhere, conclusions or opinions which are not strictly authorized by the official statement of that Committee, which, or so many members of which as participate in the experiments, shall draw up its own report of conclusions. If the individual members of the Committee are quoted or opinions or acts ascribed to them, the names of such members shall be stated in connection.

He also made this suggestion:

It has come to my knowledge that many persons are not clear in their minds that the Judges have no interest in the financial factor involved in the offer of prizes, and that they are quite independent of the *Scientific American*. This has probably come about from the facts that one of the editors of that periodical is termed Secretary of the Judges, and that the Judges' decisions have invariably and solely appeared incorporated in his articles. I suggest that the title "Secretary to the Committee of Judges" shall no longer be borne by any member of the *Scientific American* staff and that the official decision of the Committee of Judges shall, whether or not incorporated with the article describing the sittings, appear under a separate title, with the names of the participating members appended.

But although Mr. O. D. Munn assured Dr. Prince that he believed his position was perfectly correct and that his conditions and suggestions would be adhered to and gave Bird written instructions to follow them it was not long before Dr. Prince and I were forced to object to newspaper articles with such headlines as: "BOSTON MEDIUM Baffles EXPERTS," "SCIENTISTS PLAN MORE TESTS," "HOUDINI THE MAGICIAN STUMPED," "Baffles SCIENTISTS WITH REVELATIONS, PSYCHIC POWER OF MARGERY ESTABLISHED BEYOND QUESTION," "EXPERTS VAINLY SEEK TRICKERY IN SPIRITUALIST DEMONSTRATION"—and statements which, as Dr. Prince said, showed that if Bird was being correctly quoted he was telling the reporters one thing and us another. In fact we seemed unable to curb Bird until after my strenuous objection to his being in the séance room and Dr. Prince had again insisted that his resignation must be accepted unless we could have a more dependable guarantee that nothing would be said until after the series of séances was over.

Following the séances of July 23rd and 24th, 1924, Dr. Prince, Dr. Comstock, and Mr. O. D. Munn asked me to construct some sort of a comfortable restraint for the medium which would prevent her from using any of the tactics which I had detected, such as moving her hands and feet. This was agreed to by the whole Committee and I set to making a cabinet-box which was entirely closed except openings for the medium's neck and arms.

It had been arranged that the Committee should meet in Boston on August 25th. I went up from New York taking the cabinet-box along and also my assistant in case there were any changes to be made. The first séance, which took place that same evening, was in a room at the

Charlesgate Hotel.* Previous to the séance at which the Committee was present Mrs. Crandon gave a private one at which it is said there were wonderful phenomena.

At the official séance the box with the bell was placed on a table in front of the cabinet. As the lid of the cabinet was only fastened with two thin brass strips Mrs. Crandon, by lifting her shoulders, was able to force the lid and ring the bell with her head. They tried to make it appear that "Walter" had forced open the cabinet-box, which of course was simply an effort to hide the fact.

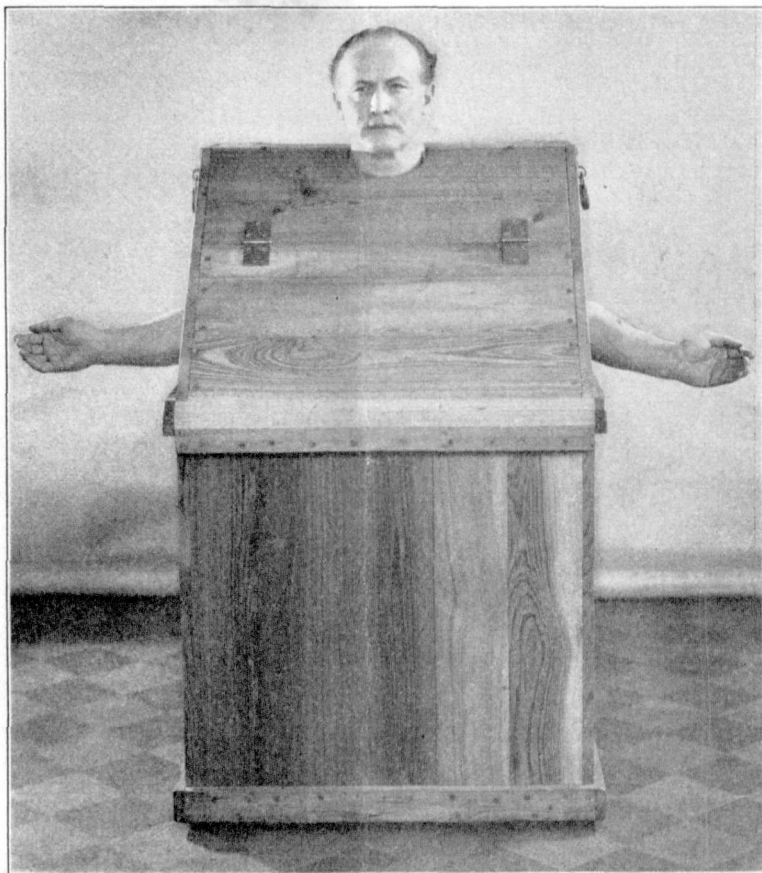

As cabinet box was first night.

The front was pushed out by medium, it being held in place by two small brass strips only.

While we were in another room, after the séance, I suddenly missed Dr. and Mrs. Crandon and walking into the room where the séance had

*The final tests were scheduled to take place at the Harvard College, but owing to the fact that Professor McDougall was traveling, Dr. Comstock thought it advisable not to go there but to a neutral place and we all agreed to use his hotel.

been held I discovered them by the cabinet-box talking in subdued tones. Their backs being toward me, they did not see me enter and I watched them measure the gap in which the neck was secured. Before that they had insisted on cutting this aperture larger, but when I spoke to them again about it, they said they were perfectly satisfied with it and to let it remain as it was.



How she pushed up the front portion of cover and opened same.

That night at the hotel after the séance while Mr. O. D. Munn and I were talking it over, he said he wanted the next séance a total blank as the fooling must be stopped. In order to do this the next afternoon I fixed up the cabinet-box so that we could lock the front portion with four hasps, staples and padlocks in such a way there would be no possible chance of the lids being forced open again.

Mr. O. D. Munn told me that he had arranged not to have Bird at the séances of August 25th, 26th and 27th. Bird though in Boston was absent on the evening of the 25th but on the 26th he came and demanded to know why it was that with no apologies he had been literally and un-

ceremoniously put out and the door of the séance room slammed in his face and what were our objections to his being present. Dr. Prince and I, in view of the disclosures which Bird had made, considered it best that he stay out. Dr. Prince is a better diplomat than I, but I openly said:



Medium can lean out and over twenty-three inches and with forehead touch bell despite fact both hands are held. All this takes place in the dark.

"I object to Mr. Bird being in the séance room because he has betrayed the Committee and hindered their work. He has not kept to himself things told him in strictest confidence as he should as Secretary to the Committee."

He denied this but I called his attention to the fact that Mrs. Crandon had told me a number of things which he only knew and that he had admitted to Mr. O. D. Munn that she had wormed things out of him.

"Well, then I will resign as Secretary to the Committee!" he exclaimed.

"That is not necessary," I replied, "as according to the letter written by Dr. Prince, the conditions of which were accepted by Mr. O. D. Munn, you can only speak for yourself and not for the Committee."

But the Committee decided to accept his resignation, as a matter of form, and Dr. Prince was elected Secretary. Bird then left the room.

This brush with Bird, and the usual preliminary examinations over, the séance proceeded. I had been asked by the Committee to construct a humane, fraud-proof restraint to hold the medium and in thinking what would be necessary to make me helpless I had figured out the cabinet-box. Then in thinking of possible ways to beat the Committee it occurred to me that were I the medium, after the cabinet was closed I could get ready, some concealed instrument, with which to reach the bell while the Committee was fastening the locks.

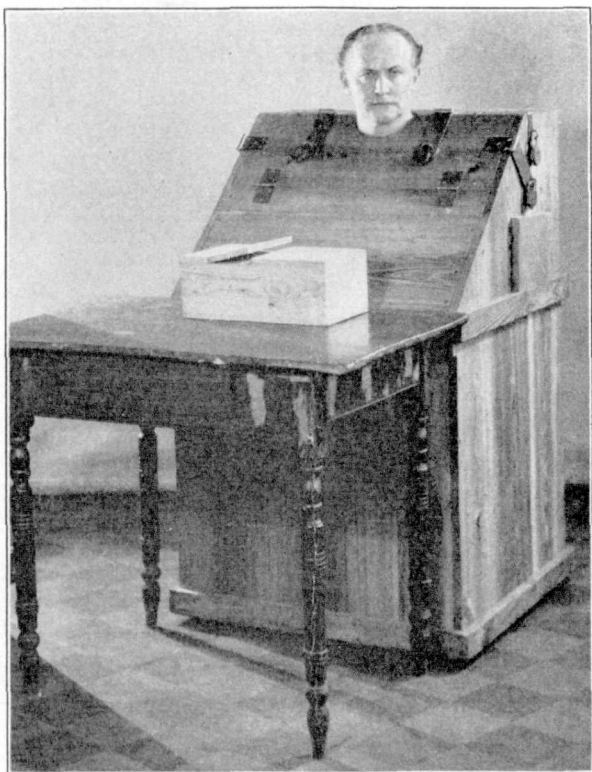

Second night—four more hasps and staples were placed on cabinet box, so medium could not force open front of box as she had done first night.

Having this in mind I allowed her the greatest freedom while she entered and was being locked into the cabinet-box, but standing at one side I carefully watched her face and could tell by the way she pulled down on her neck that she was "reaching" for something, so I asked Dr. Prince to hold her right hand and I took control of her left which she put out through the opening at my request. She was now locked in the cabinet-box with her head and arms protruding. Believing that she had something concealed, I repeatedly told Dr. Prince not to let go of her right hand until after the séance was over and the cabinet-box unlocked. I repeated

this so often that Dr. Prince not knowing what I had in mind, good-naturedly resented it, thinking I thought he did not understand. Finally Mrs. Crandon asked me sharply what I meant by saying it so often.

"Do you really want to know?" I asked.

"Yes," she replied.

"Well, I will tell you. In case you have smuggled anything in to the cabinet-box you can not now conceal it as both your hands are secured and as far as they are concerned you are helpless."

"Do you want to search me?" she asked.

"No, never mind, let it go. I am not a physician," I told her.



Front of cover open and medium can ring bell with her head. Leaning out and make no perceptible muscular movements.

Soon after "Walter" appeared in the circle saying:

"Houdini, you are very clever indeed but it won't work. I suppose it was an accident those things were left in the cabinet?"

"What was left in the cabinet?" I asked.

"Pure accident was it? You were not here but your assistant was," "Walter" went on and then stated that a ruler would be found in the cabinet-

box under a pillow at the medium's feet and virtually accused me of putting it there to throw suspicion on his sister winding up with a violent outburst in which he exclaimed:

"Houdini, you G— d— — — —, get the hell out of here and never come back. If you don't, I will!"

This just expressed Mrs. Crandon's feelings toward me for she knew I had her trapped, and despite all objections I insisted that this abusive remark be made part of the record. Dr. Comstock then suggested that in working around the cabinet-box, it was quite possible for someone to



*Medium inside and holes for arms closed.
Putting out rule enables medium to place rule in position
for ringing bell.*

drop a ruler into it accidentally. Thinking that my assistant might have forgotten or dropped the ruler I said that if it was not his I would make a statement, but I laid particular stress on a request that someone should speak to him about it before I did, so Mr. O. D. Munn left the room and brought him in. The assistant assured Munn that he knew nothing about it and told us the same, saying that it could not be his for he had that in his pocket. He then took it out and showed it to us. I made him swear to his statements with a solemn oath and he left the room.

The séance then proceeded for some time with no results and at my suggestion the cabinet-box was opened. Dr. Prince and I meanwhile

keeping tight hold of the medium's hands. After it was open I made a search and sure enough on the bottom of the cabinet was a new, cheap, two-foot ruler which folded up into a *six-inch* length.

Regarding this ruler found in the box; *I accuse Mrs. Crandon of having smuggled it in with her.* When folded up it was only six inches long and she could have done it. The stenographer, Miss McManama, who examined her was incompetent for the purpose and the reader will find, by looking up the records, that other mediums have concealed implements in, or on, their persons which those who examined them failed to find but which were discovered later when the mediums were seized by investigators.



Making use of chin to force rule down which rings bell, explains why medium smuggled the rule in.

At her suggestion, it had been arranged that in the second part of the *séance* the arm holes in the cabinet-box were to be boarded up with her hands inside free and uncontrolled. However, she could easily have stuck the rule out past her neck and ring the bell which was directly before

her on the table eight and one-half inches away.* *Mrs. Crandon, knowing that she had been caught, made the accusation to clear herself.*

The foregoing description of the occurrences at the séance of August 26th, 1924, are corroborated in all respects by the official minutes of the séance signed by the Committee.

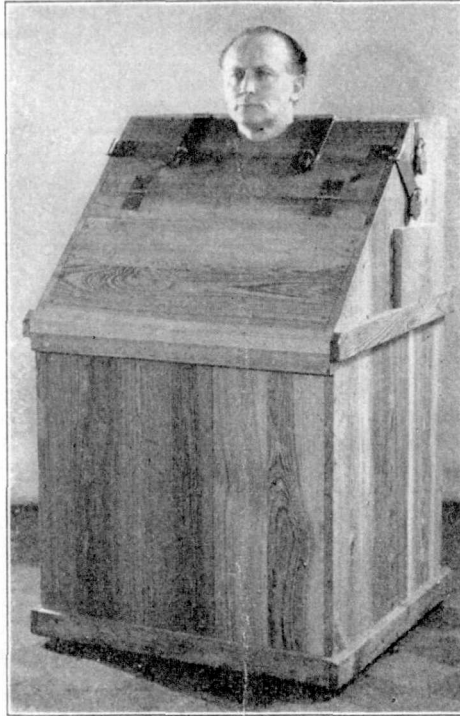

The condition of cabinet-box after I strengthened it by placing extra hasps and staples on same.

In this connection I wish to call attention to the fact that J. Malcolm Bird must have put the thought into her head because when I was describing my detection of her fraud at the first séance I attended, he said:

“You want to be careful if you grab her head, that she should not say, ‘you pulled my head down.’”

On the afternoon of August 27th, Mr. O. D. Munn, Dr. Prince, Mrs. Crandon and myself went to a dinner some distance out of Boston. At that time she told me of having heard that I was going to denounce her and say that she was a fraud, and that I had called her a liar. I asked her to tell me who it was that had told her these things but she told me that she was bound by her word not to tell but would ask permission so

*The space permitted this for the hole was eighteen inches in circumference and the night before she had demonstrated that she could push three-quarters of her hand up past her neck. It was then she was trying the space to see if she could reach with anything to press down the board which controlled the bell.

I could face my accuser. I told her repeatedly that Bird had openly confessed that as he was living at the house he was compelled to tell her something and that she had gradually wormed it out of him, but she insisted that Bird had told her nothing.

I reminded her of what she had said to me on July 24th, the day after the first séance, when she resented my giving an unfavorable report to the Committee and telling them that I had caught her foot tapping the bell, and how at that time she admitted Bird had told her but asked me not to say anything to Bird about it.

That same evening, July 24th, I protested to Mr. O. D. Munn in Bird's presence against his betrayal of our confidence. Bird denied it but I pointed out that he had been the only one to speak to her alone. I spoke to Mr. O. D. Munn about it before Mrs. Crandon on August 27th and he said that Bird admitted having told her that I had detected her fraud.

MRS. CRANDON THREATENS ME.

Being afraid that I was going to denounce her from the stage at Keith's Theatre she said to me:

"If you misrepresent me from the stage at Keith's some of my friends will come up and give you a good beating."

"I am not going to misrepresent you," I replied, "they are not coming on the stage and I am not going to get a beating."

"Then it is your wits against mine," she said slowly as she gave me a furtive look.

"Yes, certainly, that is just what it is," I told her.

She repeatedly told me of her boy twelve years old and said that she would not want him to grow up and read that his mother was a fraud, to which I replied: "Then don't be a fraud."

DR. COMSTOCK ALSO DRAWS A BLANK SÉANCE

At the séance of August 27th, Dr. Comstock insisted that the medium place her feet in a wooden box control which he had provided. This was an arrangement in which the medium and an observer, sitting opposite, put both their feet into a box which reached half way to their knees. It was so built that a board could be locked over the knees of both absolutely preventing withdrawal of the feet. The box with the bell was placed just outside this control-box at her left. No table or anything was placed in front of her. While we sat there waiting for something to happen, and her reputation depending on my report, there was a.

TEN THOUSAND DOLLAR OFFER

Mrs. Crandon remarked that she wished I would be seized with a trance for it would be a wonderful thing and her husband turning to me said:

"Some day, Houdini, you will see the light and if it were to occur this evening, I would gladly give ten thousand dollars to charity."

"It may happen," I replied, "but I doubt it."

"Yes sir," Dr. Crandon repeated, if you were converted this evening I would willingly give \$10,000 to some charity."

After an hour of waiting in which nothing occurred the séance closed having been a perfect blank, and I wish to call particular attention to the fact that in this séance with nothing in front of her on which she could use her head, and the one where she was controlled in the box which I built, with the sanction of the Committee, everything was blank.*

Although she insisted that Bird did not give her information she and her husband knew every move we were making. This was proven by the questions which Dr. Crandon asked and by the conditions which they demanded, conditions which would have been insurmountable for fraud detection if we had not resorted to the tactics which I have explained. There are no two ways about this for after the first two séances, for no reason at all except to prevent the detection of fraud, a radical change was made. Dr. Crandon insisted that Mr. O. D. Munn should not hold my left hand as he had been doing but that Dr. Comstock was to take his place and the latter had to pledge his word of honor that he would not let go of my *hand at any time and that he would control my head*. This was to prevent, by limiting my movements, any possibility of my discovering how she rang the bell or any instrument she might use, but nevertheless at many séances Bird was allowed to roam around the room at will and almost invariably had one of his hands free.

* As the cabinet-box prevented the medium from using feet, head or shoulders and her hands being securely held by Dr. Prince and myself, there were no manifestations and the séances were blanks. Turning to me Mrs. Crandon said:

"I do not believe any medium could manifest under these conditions."

"Well," I replied, "I am not so sure about that. I am not a medium, but still I could allow myself to be stripped nude, searched by your husband who is a surgeon, you control one of my hands and Dr. Crandon the other, and still I could ring the bell or tie knots in handkerchiefs that are on the outside of cabinet box."

"You must possess psychic power then," she answered.

"No," I replied, "I am just a mystifier. Do you care to put me to the test? *I'll do it right now!*"

"That would not prove anything," Dr. Comstock remarked.

"Oh, yes it would," I replied, "it would prove that these things could be accomplished by trickery."

The following letter sent to Dr. Prince is self-explanatory:

October 6, 1924.

DR. WALTER FRANKLIN PRINCE,
AMERICAN SOCIETY FOR PSYCHICAL RESEARCH,
15 LEXINGTON AVENUE,
NEW YORK, N. Y.

DEAR DR. PRINCE:

On carefully weighing the events at the Margery seances, that is the seances with Mrs. L. R. G. Crandon, and by reason of other information in my possession, I ask that Hereward Carrington be relieved from further service as a member of the Scientific American Investigation Committee.

I stand ready to justify this request at a time mutually agreeable to the Committee and myself.

With kindest regards,

Sincerely yours,
HOUDINI.

I, therefore, make the specific charge against J. Malcolm Bird that he betrayed arrangements made in private Committee conference and that the records of some of the séances in which *Bird* and *Carrington* participated are of such a nature that I must view them with grave suspicion. Dr. Crandon, writing under date of August 19th, said that the Committee had held ninety sittings of which he was in possession of the original records. The majority of these séances were attended by either Bird or Carrington and sometimes by both, but for reasons best known to Carrington he thought it advisable not to be at the séances when I was attending and although it was his right to be there he kept away. It would seem strange to any normal-minded person that when the séances were in control of one or both of these men that the most marvellous manifestations occurred but that when the medium was properly watched and controlled nothing happened.

Knowing from over thirty years of expert experience what to look for at séances and in view of what I detected at every sitting with *his medium*, if there was no complicity and if Bird and Carrington have approved the reports of the previous séances as genuine, the conclusion is irresistible that they are not qualified to sit or pass judgment on any spiritualistic investigation.

I charge Mrs. Crandon with practicing her feats daily like a professional conjuror. Also that because of her training as a secretary, her long experience as a professional musician, and her athletic build she is not simple and guileless but a shrewd, cunning woman, resourceful in the extreme, and taking advantage of every opportunity to produce a "manifestation."

I did not at first suspect Dr. Crandon being his wife's confederate. Both he and Mrs. Crandon told a story about Professor James who was lecturing to his class one day and demonstrating the effect of electricity on the heart of a frog when for some reason the battery failed to work and the Professor produced the movement with his finger thinking that as he was explaining an accepted fact the deceit was excusable. I think that Dr. Crandon believes that deceit and trickery in connection with his wife's powers are equally excusable. I now believe many things about Dr. Crandon, and, that considering his wife above suspicion he lets go of her hand without reporting it.

In closing I want to add that Dr. Prince in his original report strongly suspected the medium of resorting to conjuring and I will go on record that it has required my thirty years of experience to actually detect her in her subtle moves. They may not seem so slick as one reads of them in the open daylight but in the dark room there was no wonder that such a clever manipulator completely fooled her investigators.

The foregoing is a brief account of what I readily and immediately discerned and in absolute darkness at the five séances which I attended and if the medium has other or improved methods or claims to possess any so-called psychic power, whatsoever, I will be glad to attend further sittings with her as an investigator.

Duly appreciating that Dame Nature will eventually demand her toll and realizing that I will then no longer be here to give a personal account of my connection with these séances, I deem it a duty I owe the public to set forth the above facts for future reference.

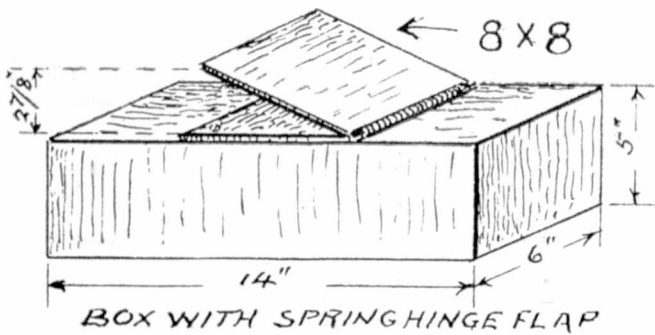
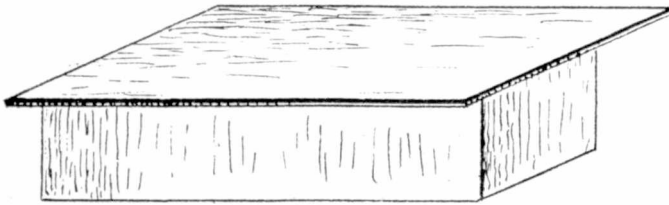
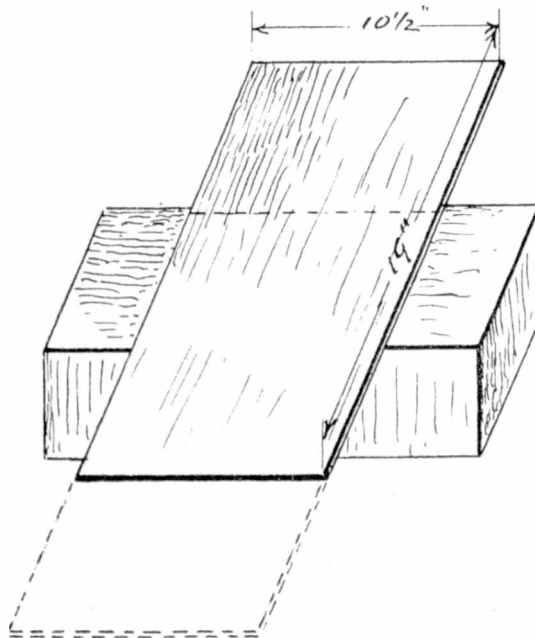

FIG. B.



BOX COVERED - FIRST POSITION



BOX COVERED - SECOND POSITION
 DOTTED LINE SHOWS PLAQUE SHIFTED

FIG. C.

The illuminated plaque or card board was placed on top of the bell box length-wise, as in Figure B, the bell box being between my two feet, but the length of the plaque enabled me to force my feet together as I wanted to see the direction from which the pressure would come, the medium being able to force it away, eventually placed the plaque on the box as in Figure C, which enabled her to get her foot on it and depress the bell.



PROVING (?) THAT A SPIRIT RINGS THE BELL

The medium is controlled. The bell box placed on the floor either to her left or right. In a short time the bell rings and the investigators are convinced of the authenticity of the medium's psychic powers.



EXPLANATION OF THE PSYCHIC POWERS

Under cover of darkness she stealthily moves the chair during the course of conversation until the bottom rung of chair forces down the hinged flap which causes contact and the bell rings.

Editorial Comments of the "Margery" Case

At the time of going to press it was impossible to gather all of the editorials together, but the following will give a fair idea of what was said editorially about the case:

Chester Balks

After a year and a half of disappointments in the great spirit hunt the prize committee of *The Scientific American* had high hopes of Margery of Boston and her "control," Chester, who lately burst into the psychic field as glorious amateurs free from all taint of commercial ambition. The sad report comes from Back Bay that a formal test of Margery's power before the scientific jury turned out to be a "blank" séance, which the most credulous could not accept as satisfactory, much less the keen investigators from the Missouri of spiritism.

Chester is evidently a temperamental spook, offish, disobliging. Heretofore he had rung bells, rapped tables, thumped heads, stopped clocks, played records and tipped scales with redundant ease. Without reward he was generous in his output of manifestations, yet on the very occasion when a \$2,500 check was at stake and, more important, the opportunity to convince scoffers that he was an authentic spirit and Margery a genuine medium, he refused to do one of these things.

It seems to be a trait common to spirits, real and false, that they dislike an atmosphere of suspicion. They do not want their human company to be too inquisitive, and least of all do they want it to be scientific. Sir Arthur Conan Doyle is a detective after their own heart, but a gentleman who knows everything about legerdemain makes them very uncomfortable.

—*New York Herald-Tribune.*

Houdini Stopped the Show!

Apparently that unquestionably "honest" Boston medium who until recently, to all except a few friends and investigators, was known only as "Margery," has excited doubts in the minds of those who were looking into the nature of her claims to supernatural or at least supernormal powers. Some of them have seen as yet

no clear reason for denying that something or somebody most conveniently called a spirit is concerned in the "phenomena" of which she is the centre, but it has been discovered that when precautions against deception have been taken that content Mr. HOUDINI, much experienced in mediumistic trickery, the spirits refuse to perform.

"Margery" and all true believers can say, "that proves nothing, one way or the other," and they are quite right. If there are any spirits with the leisure for ringing bells, throwing assorted articles about and materializing pigeons out of nothing, they have a right to insist on the conditions that suit them, and it is natural enough that they should be more than a bit particular about lights and such things.

But therein lies the next to complete hopelessness of all research in this field. Nothing in it ever is or can be settled. The "exposure" of one medium leaves the others who still are unexposed free to assert honesty to the satisfaction of those who want to communicate with the dead.

At most, only a probability can be established, and that—a very high one—was done long ago. And still the attempt to prove a universal negative goes on!

—*New York Times.*

"Margery" in the Laboratory

At the latest tests of the psychic powers of "Margery," otherwise Mrs. Le Roi G. Crandon, Mr. Harry Houdini is reported to have placed restriction on her movements which were not previously imposed. Working within these restrictions the medium was able to produce no phenomena aside from her own voice. In other words, the recent séances have been "blanks." Nothing happened which was not scientifically and easily explicable.

Unless Mrs. Crandon can do better than this, it may be assumed that her pretensions were only pretensions. When she can do her stuff in surroundings which

render fraud impossible, it will be necessary to take her seriously. No medium or fakir of the western world appears to have been able so far to give a convincing demonstration of spiritistic control under laboratory conditions. "Margery" is only the latest of a long line of claimants to such control who did not make good on close examination.

—*New York World.*

It seems that "Margery," highly successful spiritualistic medium in Boston, could not "do her stuff" in a special locked box arranged by Houdini, the magician. In another box of her own construction, bells rang, spirits brought messages about papa and mamma, and all went well.

The radio or telephone would have worked in Houdini's box. The spirits are more sensitive.

—*New York American.*
(Arthur Brisbane.)

Trust in Houdini

Houdini is not a great scientist but he is a master of tricks. Enlistment of Houdini in effort to ascertain what's what in alleged demonstrations of communication between the dead and the living, therefore, is quite appropriate.

Setting a magician to catch a medium is old stuff, but quite as reasonable as setting a thief to catch a thief. There are many who are more inclined to trust Houdini to get at the truth of the matter than any committee of psychic experts.

Houdini announces that he will not commit himself until the tests are over. For the general run no verdict is awaited with greater interest than his.

—*Buffalo Enquirer.*

Awaiting the "Chester" Verdict

So much was made two months ago of the extraordinary manifestations in the presence of members of the *Scientific American's* investigating committee at séances conducted by a Boston woman, claiming a "control," called "Mester," that much encouragement must have been given to the hope that "objective psychic phenomena" were at last to be accepted by science as at least not disproved. Apparently another disappointment is in store.

The rosy accounts given of the medium's demonstrations were written by Prof. J. Malcolm Bird, secretary to the committee—not secretary "of" the committee it is explained. It appears that certain members of the committee, not-

ably the magician Houdini, regarded these reports as at least premature. At all events, Mr. Bird has resigned his connection with the committee and at its request has withheld publication of a further article about this medium's work until the committee has reached its formal verdict and reported as to her claims. What the verdict will be the committee declines to intimate but the report is current that the medium—she is Mrs. Le Roi G. Crandon, electing at first to appear anonymously—failed under conditions imposed by the committee as a prerequisite to qualification for the \$2,500 prize.

It would be premature, under the circumstances, to pass judgment upon Mrs. Crandon's offerings, which appear, at least, to have come about the nearest yet to demonstration of outside psychic agency, but since the committee declines to say that she has succeeded, it seems likely that its report at best will be a disagreement, with a unanimous verdict that an extraordinarily gifted person has been discovered. But the "magicians" art already has a long list of accomplished practitioners.

—*Springfield (Mass.) Republican.*

"Margery's" Manifestations

It is an interesting, if not otherwise impressive, controversy that centres around the Boston spiritualistic medium known as "Margery," but who is now identified as Mrs. LeRoi G. Crandon, wife of a well-to-do yachtsman, scientist and instructor in Harvard Medical School. Something more than a year ago *The Scientific American* became interested in spiritualistic manifestations as exploited by Sir Arthur Conan Doyle, and the managing editor of that journal, J. Malcolm Bird, followed Sir Arthur about this country and England, sitting in at a number of séances. About that time it offered a prize of \$2,500 to the medium who would conclusively prove that she (or he) was able to establish communication with the other world.

Under the insistence of skeptical scientists the publication agreed to the appointment of an investigating committee, including in its ranks the professional magician, Harry Houdini. "Margery," of Boston, accomplished things which amazed and apparently convinced Mr. Bird, for he rashly rushed into print announcing that she was almost certain to win the prize. The other members of the investigating committee objected, particularly Houdini, who proceeded to impose conditions upon "Margery"—the chief being her incarceration

in an oak box, leaving only her head and arms free—which have effectively checked the bell-ringing and other manifestations attributed to her spiritualistic control.

There is nothing of particular interest in all this to the average reader except that it serves to recall the futile efforts of other mediums in times past to convince the world of spiritualistic communications. In the first chapter of his "Tale of Two Cities," Charles Dickens, writing about 75 years ago, said:

"It was the year of our Lord one thousand seven hundred and seventy-five. Spiritual revelations were conceded to England at that favored period as at this. Mrs. Southcott had recently attained her five-and-twentieth blessed birthday, of whom a prophetic private in the Life Guards had heralded the sublime appearance by announcing that arrangements were made for the swallowing up of London and Westminster. Even the Cock-Lane ghost had been laid only a round dozen of years after rapping out its messages as the spirits of this very last past (supernaturally deficient in originality) rapped out theirs. More messages in the earthly order of events had lately come to the English Crown and people from a congress of British subjects in America; which, strange to relate, have proved more important to the human race than any communications yet received through any of the chickens of the Cock-Lane brood."

The Cock-Lane ghost referred to by Dickens had mystified many of the best minds of Britain, including Dr. Samuel Johnson, before it was discovered to be a hoax; and Mrs. Joanna Southcott, described by the Encyclopedia Britannica as a "religious fanatic," has been discredited some years before Dickens began his career. Yet, it is reported, "her followers are said to have numbered over 100,000 and only became extinct at the end of the nineteenth century."

There may be in this country more than 100,000 persons who will believe in the revelations and manifestations of "Margery," even in the face of absolute proof of their worthlessness. But what are all these rappings worth? All of them, as Dickens said of similar communications 100 years ago, are "supernaturally deficient in originality."

—*Philadelphia Record.*

Houdini and Spiritism

It was a sad day for the spiritualistic "mediums" when they permitted Harry Houdini, the magician, to watch some of their demonstrations. Houdini knows

a few tricks himself and he knows them even better than the cleverest psychic frauds.

As long as they have their own paraphernalia and arrange the settings themselves, all is well; they can fool the suckers and rake in the shekels. But up Boston way Houdini produced one of his boxes for a lady medium to get into and do her "stunt." The promised messages from the other world were conspicuous by their absence.

If these people were on the level they wouldn't have to perform in the dark. If those Beyond had any word to send us they would at least sometimes speak in the broad light of day. Why apparently intelligent persons "fall" for these "shell game artists" and relinquish good money to them is something we never could understand. Time and time again they have been exposed.

The souls of the dead scratch no messages on greasy slates for stupid eyes, shout none across the Styx that can be heard by vulgar ears; although there beloved ones left behind, who in the silent communion of their own thoughts can hear the music of lips silent to others, can feel the presence of him or her held dear in the long ago. The veil that separates the two eternities is not an impenetrable wall, but a sacred shadow through which is wafted the soft incense of love.

But these mediumistic swindlers, exposed by Houdini on many occasions, make a mockery of that "inspiration of the human race" which the great Beecher said "flows directly from the bosom of God." They would have us believe the souls of the departed ones are hiding in bat caves by day and snooping around in "ungainly hours of night" to seek dark-lantern séances with ignorant fortune tellers.

More power to Houdini to run the fakirs out of business.

—*Providence News.*

Margery Fails

Not since Sir Arthur Conan Doyle made his tour of the United States several years ago has there been such an interest in so-called psychic phenomena as has been aroused by the experiments of Margery, the wife of a prominent Boston surgeon and professor at the Harvard medical school. The principal witnesses at Margery's latest séances have been Harry Houdini, the stage illusionist, and a committee, appointed by the *Scientific American*, which offers a prize for

genuine manifestations of psychical powers.

The position in life of the medium and the gravity and scientific attainments of the investigators will bring serious attention to the séances from quarters which heretofore have been the source of frivolous comment on the subject. Nevertheless, the skeptical will not fail to note that a solid oak cabinet devised by Houdini prevented ghostly activities in a locked room where a pigeon had whirred, bells had tinkled and a being had whistled when the medium had been confined to a less substantial box. Ectoplasm apparently cannot exude through inch-thick oak, or the control has been frightened away by the lack of sympathy on the part of the investigators. One is inclined to think that the lack of sympathy was more effective in making the séance a blank than the oak cabinet, for spirit photographs displayed by Doyle and the lesser believers show the ectoplasm exuding from the medium's neck. Margery's head and hands were outside the cabinet.

—*Buffalo Express.*

Bah Blah and Ba, Houdini can—and will—if given the opportunity—show up the entire fraternity of the self-styled bridges between the known and the unknown.

I have received about twenty newspapers from various parts of the U. S. stating that Houdini had discovered the secret of "Margery's" séances with her "control" Chester and whether or not Mr. Munn of the *Scientific American* believes in Houdini's statements, I do. As an ethical physician it seems to me a rather low and despicable thing for a noted surgeon such as is the husband of "Margery" to allow her to engage in such conduct, even if it were true that she communicated with the dead through a brother who is dead.

—*The Sphinx.*
Sept., 1924.

The Quest Eternal

The "New York-Herald-Tribune" yesterday morning noted that the committee of psychic experts who have been interested in the powers of a strictly non-commercial Boston medium are now in rough water. The members decline to discuss the matter, but it appears that a series of articles as to the medium by J. Malcolm Bird, two of which have already been printed, has been interrupted,

Mr. Bird announcing that the September instalment has been withdrawn for reasons which would appear in the October issue of the "Scientific American."

Mr. Bird, so the "Herald-Tribune" asserts, was in attendance at séances on Monday and Tuesday evenings of this week, despite the protests of some members of the committee who said that he had betrayed their trust in giving information to the press before the completion of the tests. It was said that he was not present on Wednesday evening, having been sent back to New York by O. D. Munn, publisher of the "Scientific American."

The tests, so it is alleged, went on well until Houdini attended. Since that occasion or occasions the committee refuses to say whether the tests were blank or otherwise. Houdini is quoted as follows:

"The woman may be genuine, as they say. I will not commit myself until the tests are over. But there will be further tests. As cases of this kind excite too many people, disturbing them and giving them hope for communication with the dead. If "Margery" can give that communication, all right; but if she can't I want to do something more for humanity than entertain it.

"Margery" it is only fair to say, is doing nothing for hire, neither is she poor or illiterate, but the "Herald-Tribune" infers that when Houdini is present, her control, "Chester," declines to manifest himself and without his co-operation nothing mysterious appears. "Margery" has no control over "Chester's" movements and there is nothing to excite the interest of the members of the committee in his absence.

Mr. Bird's experience in the past has not been of a sort to render him unduly hopeful, hence his enthusiasm as to the feats of "Margery" has surprised those who have followed his work, but now they suspect, as he may, that he has been disappointed, a conclusion which may be arrived at without discredit to the medium.

What is evident is that the question remains unsettled. Those, and there are many, who believe that discarnate intelligence can communicate with humans, will see nothing to shake their belief in the refusal of "Chester" to exhibit his power in the presence of one who doubts. Those who deny the theory of spiritism will be strengthened in their unbelief and will say "I told you so!" Again we see a drawn battle.

—*Hartford Courant.*

Magician and Medium

The psychic inquiry committee named by the *Scientific American* to supervise its mediumistic tests acted with prudence when it enlisted the services of Harry Houdini, in the case of "Margery." This medium, it will be recalled, had all but persuaded the committee that she should receive the magazine's long-standing award for the production of phenomena beyond the physical. The committee had announced its confidence in the genuineness of her psychic demonstrations. But a native cunningness stayed the hand that held the purse. "Margery" was first required to undergo a test séance under the supervision of Houdini.

Perhaps it was a disappointment to many of us to read that "Margery" failed to pass that final and all-important examination. When locked in a cabinet of her own construction she was still the marvelous "Margery" of old, seemingly in control of supernatural facilities. But when locked in a cabinet devised by Houdini, master trickster, her strange powers deserted her and all tests were negative. And the award for which she strove awaits another medium, if one competent to win it shall make the endeavor. As for our disappointment, we should reflect that it was the truth we were reaching for and not delusion.

A great many questions arise from this latest failure to touch the fringe of another world. Was "Margery" sincere, and being sincere, was she herself deluded? She is a woman of good social position and excellent character, report has it. Or was she a conscious charlatan, preying upon the field of human sentiment? Or is it possible, as the spiritists maintain, that mediumistic ability is often repressed by untoward circumstances and a critical audience, and, if so, why?

—Portland Oregonian.

"Spirit" Tests Ended by Occult Student

Boston, Aug. 28.—The latest series of tests to determine whether Mrs. Le Roi G. Crandon, wife of a surgeon of this city, who has been known as "Margery" to the world of psychic students, could induce phenomena that would win award to her of the *Scientific American's* prizes for such genuine feats, ended last night with results said to be both positive and negative.

In a big black box, fashioned out of inch thick oak in the manner of an old-time pillory, the medium was said to have

failed to invoke proof. In another box, somewhat similar, but with more freedom, results were positive, bells being rung and messages transmitted, it was said.

The tests, still incomplete, have resolved into a trial of the two types of boxes. The oak box is the property of Harry Houdini, the magician, who is a member of the committee. It is understood, however, that the committee has not accepted this box as an official test, because the committee as a whole has not had an opportunity to examine it. The second box is the committee's cabinet evolved for such tests, with the medium under padlocked restriction, the bells confined beyond ordinary reach, and safeguards inserted to prevent fraud.

The tests were understood to have developed an uninterrupted series of positive manifestations, including the appearance of lights, whistling, chairs moving across the floor, and a pigeon whirring through a room in which doors and windows were locked until Houdini brought his box.

—The Press, Long Beach, Calif.

If there is one man in this country whose activities the busy-bodies should curtail, that man is Harry Houdini, "handcuff king." No sooner does some "spirit" medium, etc., come to the fore with great claims of mysterious powers that gain him or her a great following of credulous Yankees, including not a few so-called scientists who are always waiting to be baffled, than Houdini appears on the scene and explains how the "spirits are moved." Houdini is doing his best to keep down the sucker rate, but he has a man-sized job on his hands for fair.

The latest to run afoul of the handcuff king is the more or less mysterious "Margery," of Boston. She had attracted wide attention by her ability to make pigeons fly about the room where there had been no pigeons before; she merely said the word and lights appeared where had been darkness; ectoplasm "ectoplasmized" all over the room at her beck and call; a group of scientists held séance after séance with "Margery," at the end of which the learned men confessed that, like the usual run of detectives following the commission of a crime, they were duly baffled. The men of science announced that they had taken every precaution to prevent fraud on the part of "Margery" and that her "spirit manifestations" were truly genuine.

Then Houdini appeared on the scene. Houdini is the original Missourian, born and bred; he has to be shown. If "Margery" were all she and her friends claimed her to be, argued Houdini, let her do her stuff in a cabinet of his own making. Previously "Margery" had performed her stunts in a cabinet built by herself. She agreed to Houdini's terms—and the next "séance," carried out under the direction and watchful eye of Houdini, was a complete and total loss. Not one of "Margery's" favorite "spirits" appeared on the scene, neither did any pigeons flit about the room, nor did

mysterious lights or ectoplasm put in an appearance. The show was a bust from start to finish. One or two of the so-called scientists resigned from the commission following Houdini's exposure of "Margery," but others have stuck to the ship because, as they say, Houdini's test wasn't a "fair" one. In other words, the handcuff king had neglected to provide his cabinet with pigeons, etc., hence "Margery," as an intimate friend of the "spirits," turned out to be but another oil can.

—*Catholic Observer, Pittsburgh, Pa.*

Joaquin Maria Argamasilla

The Spaniard with X-Ray Eyes

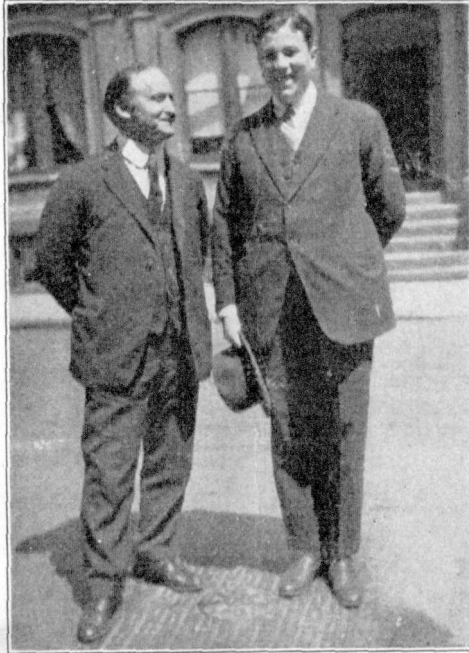

HOUDINI AND ARGAMASILLA



HIS phenomenal mystifier essayed to perform or accomplish the impossible; he makes claim to a power of supernormal vision, X-Ray eyes and a penetrating brain; however, his claim to supernatural power was acknowledged as being limited, seemingly not familiar with the English language, he is always accompanied by his promoter who served in capacity of interpreter.

This promoter presented Argamasilla as a youth of nineteen, his appearance and mannerism indicates a more mature personality. As credentials, this young man brought letters purporting to have been written by the Noble prize winner, Prof. Richet, and from Prof. Geley; likewise, from noted scientists of Spain who attested the fact that Argamasilla, unqualifiedly, came through all tests and that he had proved conclusively to their satisfaction *that he could read through metal*.

It was claimed the Spaniard, with his X-Ray eyes, could penetrate metal *provided it was unpainted*. Giving precedence to gold—and in sequence, silver, copper, zinc, tin and iron. His most popular test was the reading through the hunting case of a watch. The hands of which having been set at random just before the watch was placed in his hands; and that is just what, seemingly, he did, to the amazement of scientific onlookers—and this youth's handling of the watch was so innocently done as to ward off suspicion.

As is the case, always, with the first presentation of such unnatural things, a weird, uncanny impression is made on the mind of the lay investigator; having been thrown off guard by the art of misdirection he is susceptible to the superstitious element lurking in the minds of the assembled gathering—there is infection to existing superstition, particularly so when logical deduction seems foreign to the production.

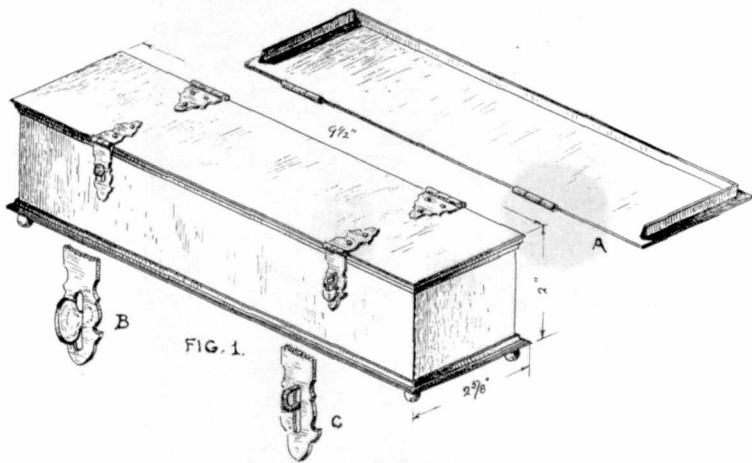

Aside from reading through the closed hunting case of a watch—this Spaniard lays claim to visually penetrating metal when in the form of a box. It is true the box must be of convenient form and unpainted. Argamasilla carries two types of boxes, one made of solid silver, represented by illustration, Fig. 1, the top or lid of which is hinged to back wall and secured at front by two hinged hasps, but it will be noticed that one of these hasps is engaged by a *turn buckle*, "B," while the other one is fitted to a projecting *staple* "C," to accommodate a small padlock. The underside of lid "A" is provided with a flange at the two ends and along the entire length of the front edge, and this flange serve to intensify the mystery, as it apparently renders surreptitious opening, revealing a view of interior, impossible.

The other type of box is represented by Fig. 2, three walls of which are crowned with horizontal flanges in conjunction with lug strips on each end wall under flanges, constitutes a runway for a sliding lid.

The front wall is minus such flange, but, centrally situated, it has a flange lug bent at right angles and projecting upward. The sliding lid has a similar lug and both are pierced to accommodate a small padlock.

This box is of sheet iron, or *steel*, and since the visual performance is supposed to take place as result of penetration through the metallic lid, to demonstrate economically, the one box is made to serve the purpose with lids of copper, zinc, tin and iron.

The watch; any hunting case watch borrowed from a spectator serves the purpose. There is no special preparation to make; it is only necessary that the hands be so shifted as to disguise the correct time and to prove the genuineness of the reading. So, the Spaniard's method of procedure is simply to ask for a hunting case watch, with request that the setting of the hands be done optionally with the holder; while this is being done, he proceeds to blindfold his own eyes with his own handkerchief which has been already prepared by folding, and as this lays across his left hand he adjusts two wads of cotton batting, ostensibly, pads for each eye, and at once applies the bandage to his eyes and ties it at back of his head. He is now ready to receive the watch in right hand, face up but case closed.

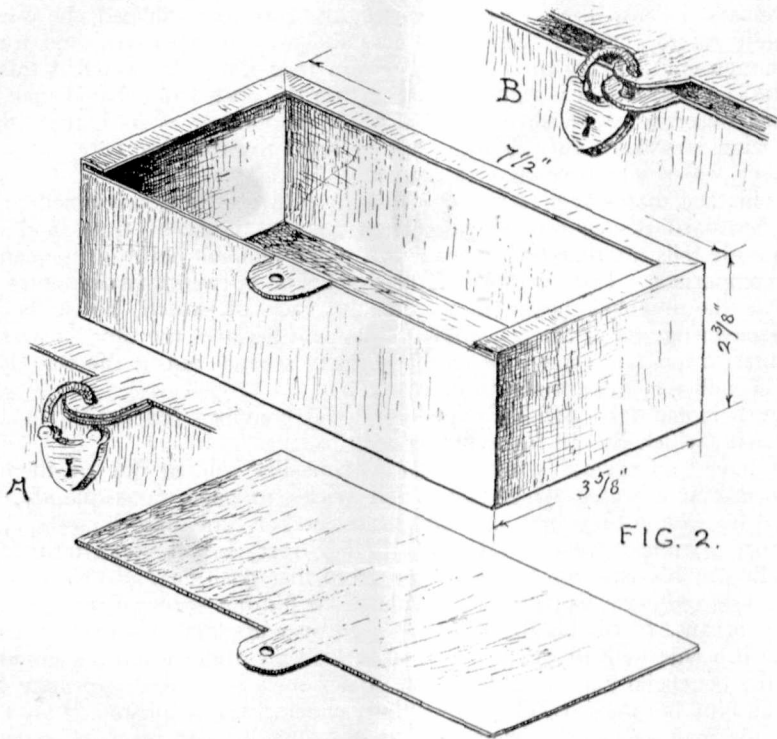

He disclaims power to look through the works of a watch, therefore, logically requires the face to be on the uppermost side. He receives the watch, holds it gingerly in a horizontal position between the index finger and thumb for a moment or two. He then raises the hand with watch between the same fingers, to such position that watch is vertical and at a height about to his chin. After a moment he lowers the hand with a sweep, and in so doing lowers the watch to a horizontal position in the palm of hand with the stem head resting against the ball or root of thumb,

and hinge of case against ring and second fingers, simultaneously he exerts sufficient pressure by ball of thumb to spring case open which is covered and guarded by the flexed fingers. The watch case is opened but a trifle, perhaps $\frac{1}{2}$ to $\frac{3}{4}$ of an inch, and a quick glance is all sufficient for the reading, and this is made possible, as watch is held so low that a downward glance on line of cheeks, beneath handkerchief, gives a perfect line of vision, this is facilitated by the cotton pads previously referred to, which when applied, rest on the brows, rather than directly over the eyes, also by "knitting the brow" and raising again, rides the handkerchief up and opens a line of vision, in which case the watch is seen with the greatest ease.

I have seen this man place his left hand to his forehead and by so doing almost imperceptibly raise the handkerchief to improve his downward line of vision.

A glance having been gotten at watch, and time noted, pressure by ball of thumb at same time, fingers press lid closed, by this combined movement the watch is noiselessly closed, and this accomplished, the watch is again raised vertically before the eyes and manoeuvred back and forth as though endeavoring to get it to a certain focus. As the watch is raised to the last position, it is caused to lay flat on the open palm that it may be visibly observed to be closed. This whole manoeuver is so natural that suspicion is warded off and the back of hand toward observers forms a perfect screen when watch case is open.

This last manoeuver is simply acting, and during time consumed by it the Spaniard makes mental calculation for the *lapse* of time, and so, seemingly tells the time as he sees (?) it just a moment before it is opened for comparison. For example, if the exact time is twenty-two minutes to ten at the moment he actually sees the face of watch, he stalls by manoeuvring and at the psychological moment declares the time as twenty minutes to ten, and though he might be thirty seconds out of the way, it is not of sufficient importance to note.

A personal trial of this experiment will convince the reader of the ease with which its can be accomplished.

I have had several sittings with Argamasilla, and at one of them I handed him a watch which was itself tricky to open, consequently, he failed to tell the time by that watch. At another time, at the Newspaper Feature Syndicate office, 241 West 58th Street, I had opportunity for standing at his extreme left side and from that position *I positively saw him open and close the watch*. Of course, he did not know of my vantage point, because of his blindfold, as I looked over his left shoulder.

It is a rule with this man, to stand back in a corner close to a window, for the beneficial play of light, also that no one of the observers may get behind him, but my favorable opportunity clinched my suspicion.

This man is a very clever manipulator, and he acts his part in such manner as to insure misdirection.

Since witnessing his performance I have presented the watch trick and so far no one has been able to detect the movement unless knowing, before-hand, the trick of opening and closing the watch.

The handling of the boxes varies considerably from that of the watch—but that too, will be made clear by accompanying illustrations.

Giving first, attention to the silver box. A printed card or small slip of paper with writing, placed in box, lid closed and locked with one small padlock and the second hasp secured by the turn buckle. The operator

holds the closed box by a hand clinching each end and in his manoeuvring twisting and slightly swinging the box from side to side, he manages to drop the left hand and by aid of the thumb lifts the lid at the left corner, see Figure 3. Just before raising lid and during manipulation he manages to release turn buckle so hasp slips free.

The right hand is so placed as to expose that end of box, at times by merely balancing box on finger ends, a firmer grip when required, is obtained as shown in Figure 3. In course of manoeuvring, the card is brought to a favorable position for reading by successive joltings of box, the left end being lowered and turned away from observers the fact that box is opened is unobserved by them.

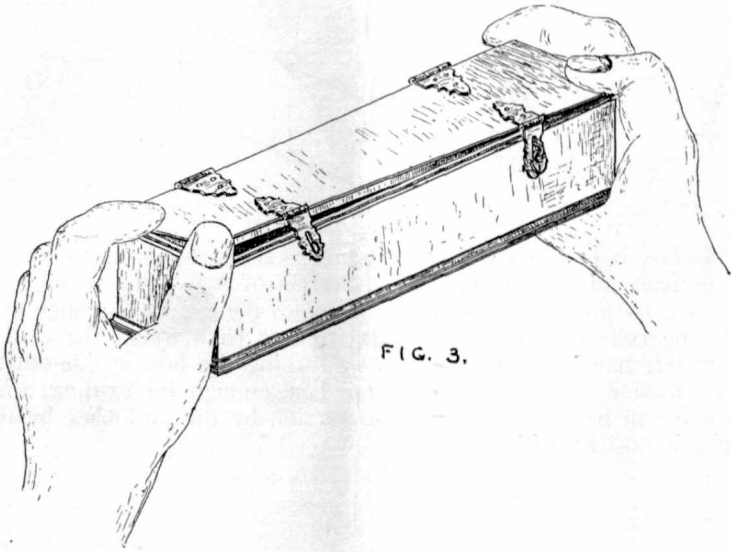

The view shown in Figure 3, is as seen by the operator himself. The audience, or observers, see the back of box and its end only as held or poised on fingers of right hand. The box is also held at such an angle that the observers do not get a view of top of it.

It should be noted that Argamasilla always chooses a position with light behind himself, and such that observers are always *in front*, facing him, he very adroitly guards against observers being at his side or behind himself.

The box with sliding lid is handled differently, necessarily so, because of its particular form of construction. The casual observer on first examination, being unfamiliar with the mode of handling is unprepared for a critical examination, consequently he does not notice that the metal of lid is quite flexible, and that the running grooves at ends of box are so free as to afford sufficient play by raising the lid—just a trifle, but “*every little helps.*”

The runner flanges around three edges of lid, and projecting lugs for attaching a padlock, would seem proof positive against possibility of trick, but the innocent observer has failed to note the fact that the bow, or shackle is elongated a trifle, perpendicularly. It looks innocent enough

when seen in its normal position (Fig. 2-A), but that innocence is soon dissipated when viewed as shown at "B." This opening is made possible by the fact that the front edge of the lid projects a fraction of an inch beyond the front wall of box, which affords a purchase for the left thumb without resorting to pressure on the lugs, the flexibility of metal and slight play in runners makes the opening possible. "B", Fig. 2, is slightly erroneous in drawing, the horizontal edge could slant slightly downward both ways from the lug converging at the ends of box where held by the running grooves.

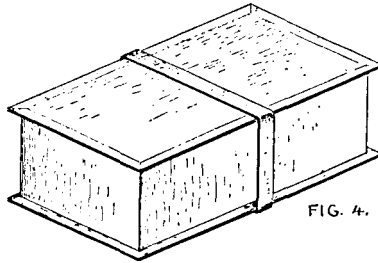

FIG. 4.

The box is held practically the same as the silver box, reading of the card is made possible by variable deflection of both light rays and visual beam, and by proper manipulation of angles the eye has a range of practically the full bottom of box from front to back walls; the card being kept in left hand corner of box. By turning the box upside-down it is an easy matter to slide the card out of box, enough for reading, and even at that it can be obscured from observation by the on-looker by the angularity in position of holding box.

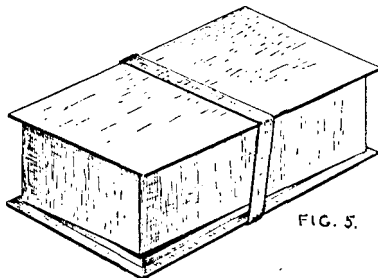

FIG. 5.

Fig. 4, represents a Park & Tilford Nut and Fruit box made of tin, its lid has vertical flanges to fit into box on all but hinge side, and in lieu of a lock, the lid is held in place by an elastic band, this box is covered on all sides with colors from black to gold, the mass of color being black, nevertheless, and notwithstanding the ban Argamasilla puts on painted metal, he did accept this box for a test, and safely so, because a casual examination shows the lid securely hinged, but the means of holding lid closed is so *elastic*, that the manipulation made necessary became identical with that for the silver box; however, Argamasilla took precaution to turn box upside down to facilitate reading as shown in Figure 5. Under which conditions the possibility of reading is made perfectly clear by Fig. 6 and